

THIS DRAWING IS A CONTROLLED DOCUMENT FOR SOURIAU USA, INC. IT IS SUBJECT TO CHANGE WITHOUT NOTIFICATION. CONTACT THE DOCUMENT CONTROL CENTER FOR THE LATEST REVISION.

ELECTRICAL:
 EMI SHIELDING : SHIELDED FOR THE RANGE 55dB UP TO 100MHz
 INSULATION RESISTANCE : >500MΩ PER ANSI-EIA-364-D METHOD 21
 MAX. CURRENT RATING : SEE INSULATOR DRAWING
 CONNECTOR TESTING : SEE INSULATOR DRAWING
 CONNECTOR WORKING : SEE INSULATOR DRAWING
ENVIRONMENTAL:
 ENDURANCE: 1000 CYCLES AS PER MIL-STD 1344A, METHOD 2016.1
 SHOCK: 50 g , DURATION 6 ms; AS PER MIL-STD 1344A, METHOD 2004.1
 VIBRATIONS: 10 TO 2000Hz g = 20g, AS PER MIL-STD 1344A, METHOD 2005.1
 PROTECTION INDEX: IP 40 AS PER IEC 529
 ROHS COMPLIANT
 SALT MIST : 48Hr PER SAE AS 1344 METHOD 1001.1 CEI 529
 OPERATING TEMPERATURE: -55°C TO +125°C (-67°F TO +257°F)

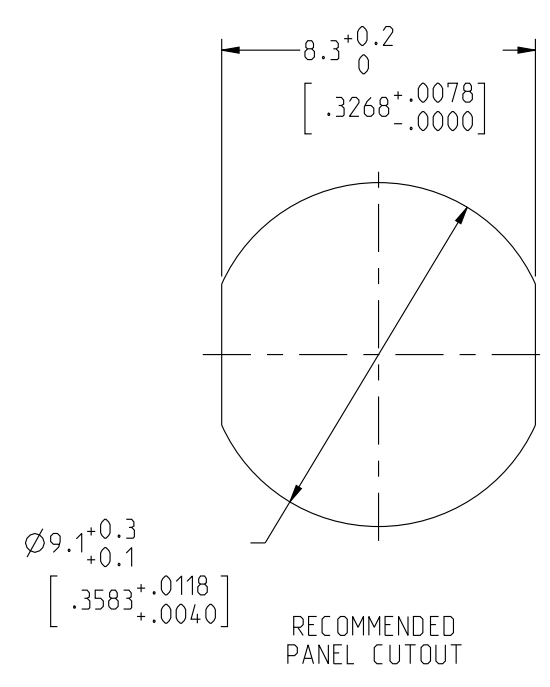

NOTES:
MATERIAL:
 OUTER SHELL & PANEL NUT : BRASS
 SHIELD RING & NUT :
FINISH:
 OUTER SHELL & PANEL NUT : CHROME
 OTHER BRASS PARTS : NICKEL
TOOLS

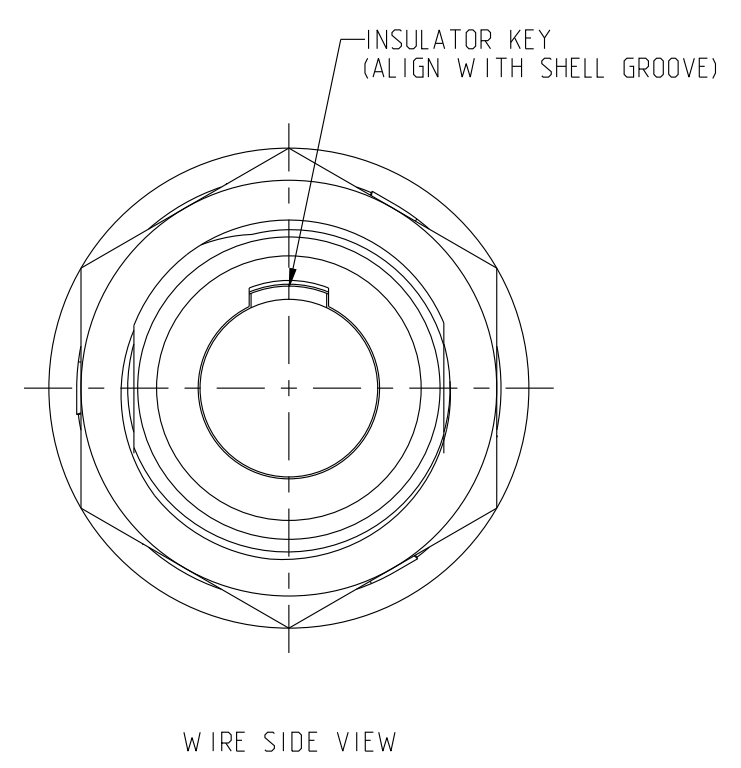
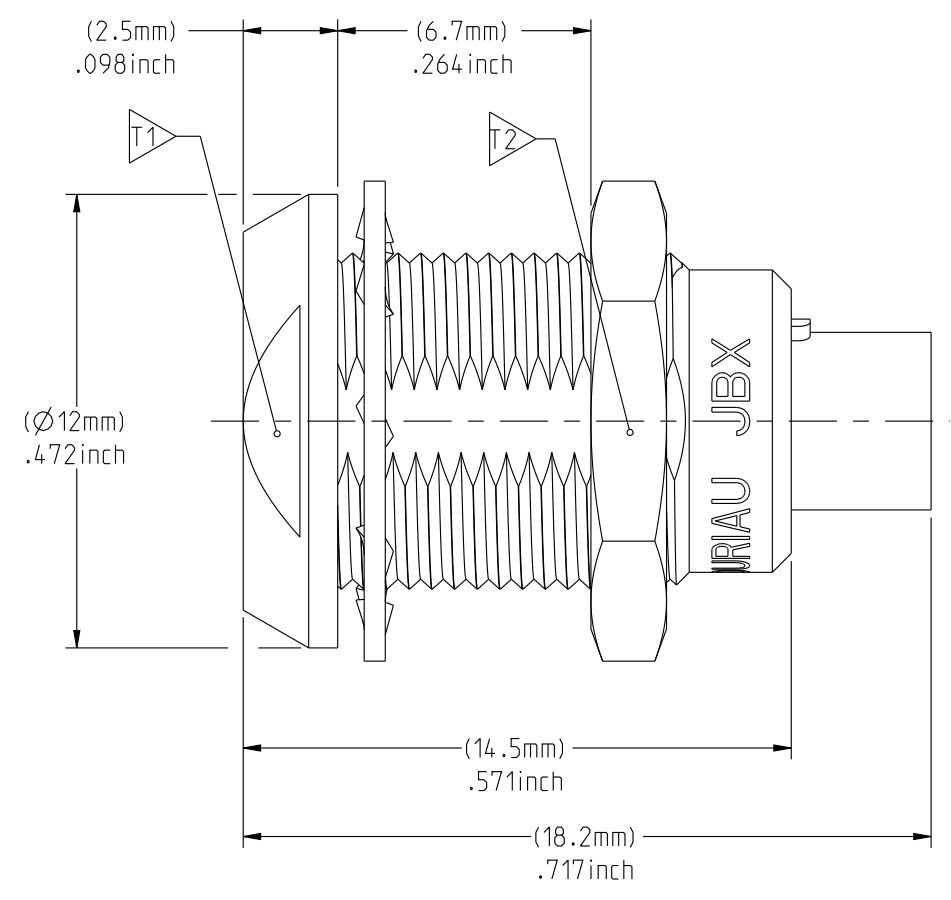
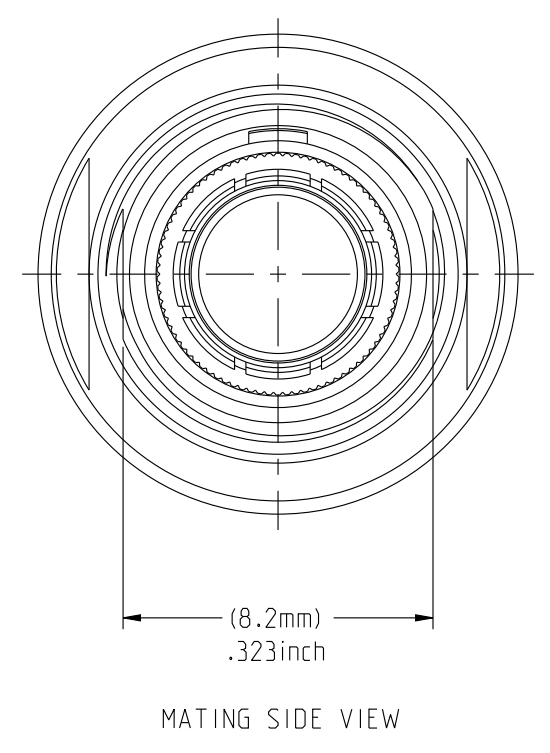

PART LIST	
ITEM NO.	DESCRIPTION
1	SHELL
2	PANEL NUT
3	HEX NUT
4	INSULATOR
5	LOCK WASHER

	TOOLS (JAW DIMENSION)	ADVISED TORQUE IN Nm
T1	10	0.7
T2	11	0.7

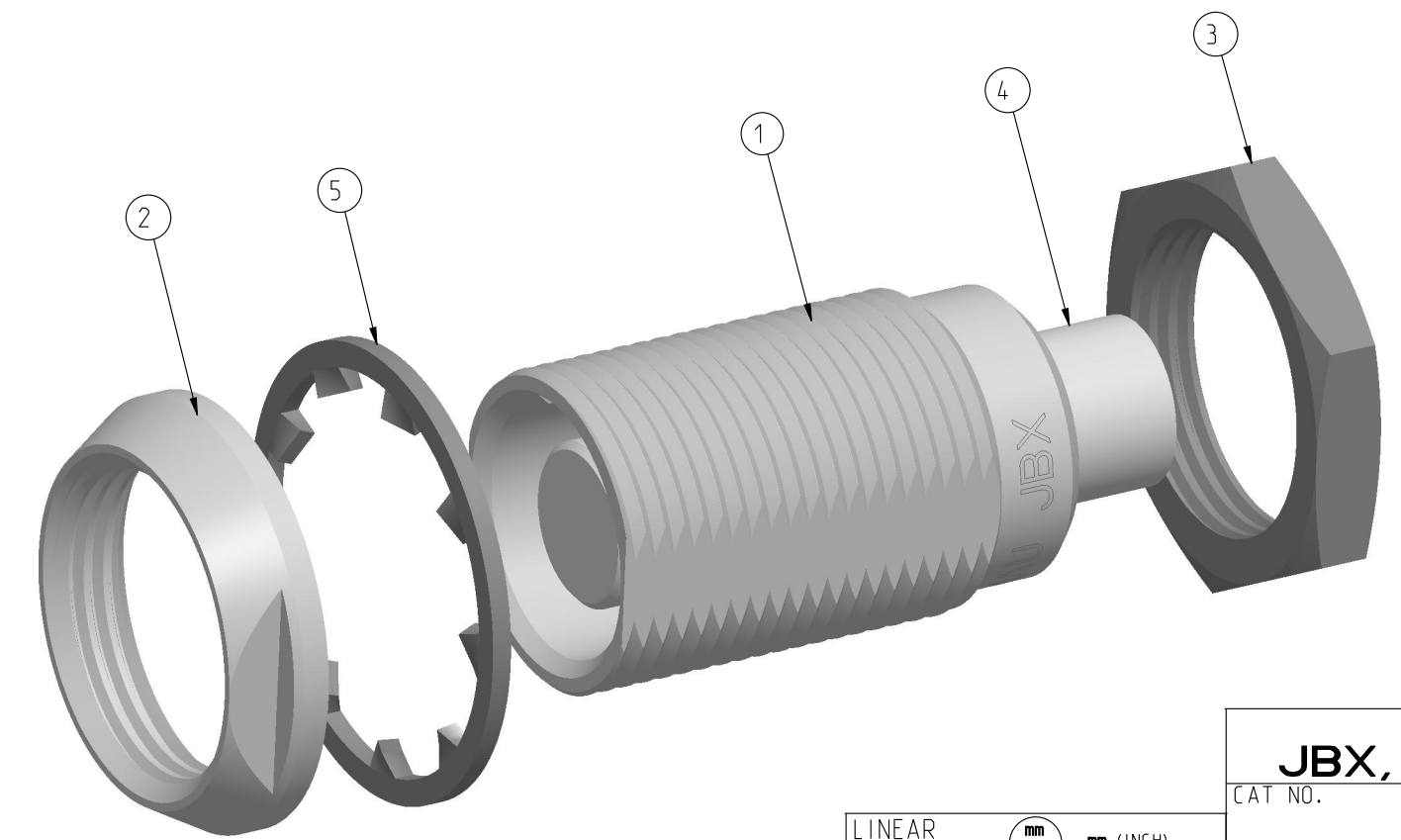

CATALOG NUMBER DESCRIPTION

JBX EA 0 XXXXXDX -

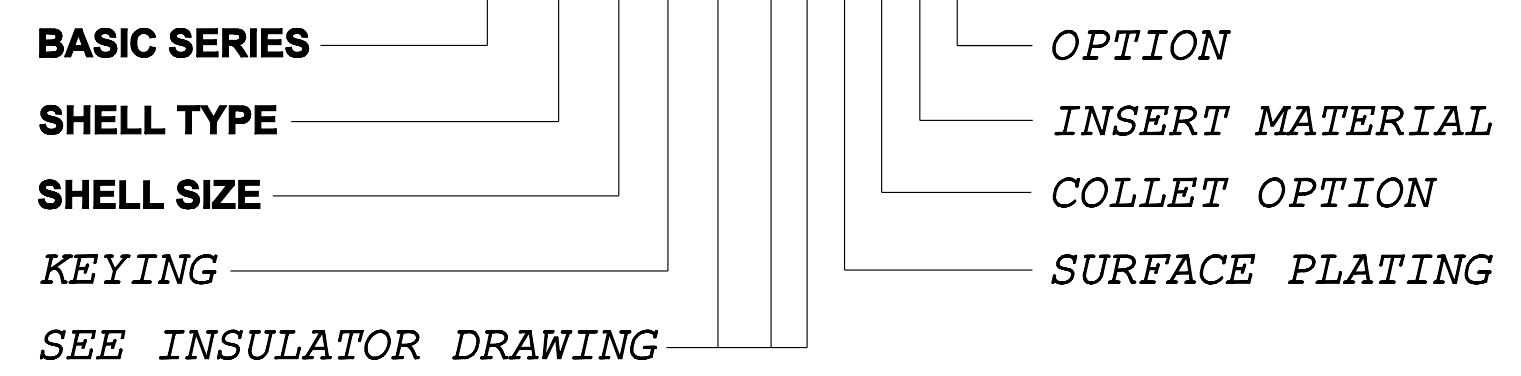

ORIGIN	COUNTRY	JURISDICTION	CLASSIFICATION
X	FR	Not listed	N/A
	US	EAR	ECCN =EAR99

These commodities, technology or software are exported from the United States in accordance with the Export Administration Regulations. Diversion contrary to U.S. law is prohibited.

LINEAR MEASURE:	mm (INCH)
THIRD ANGLE PROJECTION	
TOLERANCES UNLESS OTHERWISE SPECIFIED	
No. OF PLACES	mm [INCH]
WHOLE No.	±0.5 [±.02]
ONE PLACE	±0.2 [±.008]
TWO PLACES	±0.1 [±.004]
ANGLES ±1°	

DRAWING TITLE
JBX, SIZE 0, DOUBLE NUT RECEPTACLE

CAT NO. **JBXEA0**

CAGE NO: 09922 SIZE: C

CUSTOMER

INTERPRET THIS DRAWING IN ACCORDANCE WITH ASME Y14.5M - 1994.

SOURIAU
 WWW.SOURIAU.COM

APPROVAL
 DRAWN: TJS 01-07-15
 CHKD : EV 01-07-15
 DSGN : EV 01-07-15
 MFG : DH 01-07-15
 QC : BB 01-07-15
 DRAWING SCALE: 5:1
 DRAWING NO. **JBXEAOC**
 REV A

1 OF 1

DWG. NO.
JBX01NSMPC

MALE INSULATOR, STRAIGHT PCB CONTACT

CONTACT LAYOUT	04	05	06	07	08
FRONT SIDE VIEW					
REAR SIDE VIEW					
CONTACT					
ISO VIEW					
CONTACT	ØC	0.7	0.7	0.5	0.5
	ØF	0.5	0.5	0.5	0.5
	MAX. AWG	-	-	-	-
	MAX. CURRENT RATING (A)	7	7	5	5
INSULATOR	CONTACT RESISTANCE (mΩ)	5	5	10	10
	NUMBER OF CAVITY	4	5	6	7
	MAX. CURRENT RATING	7	6.5	2.5	2.5
	TEST VOLTAGE (Vrms)	1350	800	680	680
WORKING VOLTAGE (Vdc/Vrms)	660/460	400/260	320/220	320/220	190/130

CONTACT TYPE : M (MALE)
CONTACT TERMINATION : P (PCB)
MATERIAL :
 CONTACT: BRASS
 INSULATOR: PEEK
FINISH :
 CONTACTS: GOLD

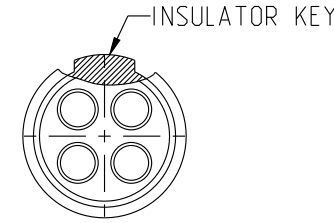

CATALOG NUMBER DESCRIPTION

JBXXX 0 XYYMP XXXX

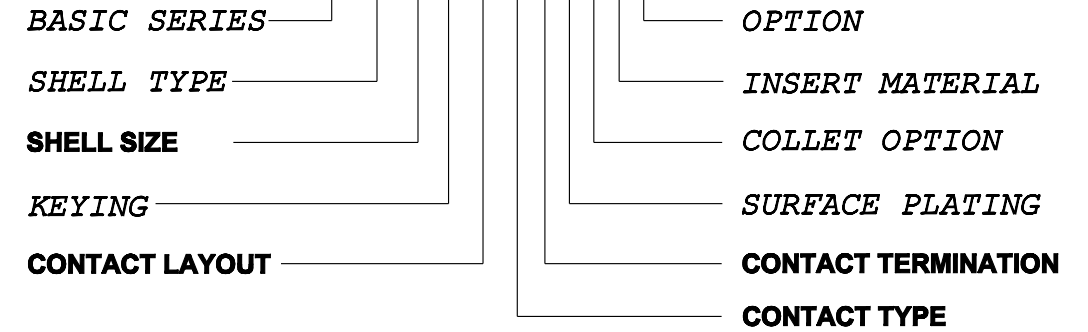

B	REVISED PER ECN 12286	RSK 06-10-15	EV 06-10-15
A	RELEASED PER ECN 12264	SKV 03-10-15	EV 03-10-15
REV	DESCRIPTION	BY DATE	CHKD DATE

DRAWING TITLE

JBX, SIZE 0, MALE INSULATOR, PCB CONTACT

CAT. NO. JBX01NSMP		DRAWN: SKV 02-02-15	
CAGE NO: 09922	SIZE: B	CHKD : EV 02-02-15	
CUSTOMER	SOURIAU	DSGN : EV 02-02-15	
		MFG : DH 02-02-15	
INTERPRET THIS DRAWING IN ACCORDANCE WITH ASME Y14.5M - 1994.		QC : BB 02-02-15	
WWW.SOURIAU.COM		DRAWING SCALE: NA	
		DRAWING NO. REV	
		JBX01NSMPC B	
		1 OF 2	

THIS DRAWING IS A CONTROLLED DOCUMENT FOR SOURIAU USA, INC. IT IS SUBJECT TO CHANGE WITHOUT NOTIFICATION. CONTACT THE DOCUMENT CONTROL CENTER FOR THE LATEST REVISION.

THE INFORMATION CONTAINED IN THIS DRAWING IS CONFIDENTIAL AND MAY NOT BE DISCLOSED WITHOUT WRITTEN CONSENT FROM SOURIAU USA, INC.

ORIGIN	COUNTRY	JURISDICTION	CLASSIFICATION
X	FR	Not listed	N/A
	US	EAR	ECCN =EAR99

These commodities, technology or software are exported from the United States in accordance with the Export Administration Regulations. Diversion contrary to U.S. law is prohibited.

LINEAR MEASURE: mm (INCH)

THIRD ANGLE PROJECTION

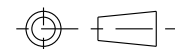

TOLERANCES UNLESS OTHERWISE SPECIFIED

No. OF PLACES mm [INCH]

ONE PLACE ±3 [±.1]

TWO PLACES ±0.5 [±.02]

THREE PLACES ±0.25 [±.010]

ANGLES ±1°

B

A

THIS DRAWING IS A CONTROLLED DOCUMENT FOR SOURIAU USA, INC. IT IS SUBJECT TO CHANGE WITHOUT NOTIFICATION. CONTACT THE DOCUMENT CONTROL CENTER FOR THE LATEST REVISION.

THE INFORMATION CONTAINED IN THIS DRAWING IS CONFIDENTIAL AND MAY NOT BE DISCLOSED WITHOUT WRITTEN CONSENT FROM SOURIAU USA, INC.

DWG. NO.
JBX01NSMPC

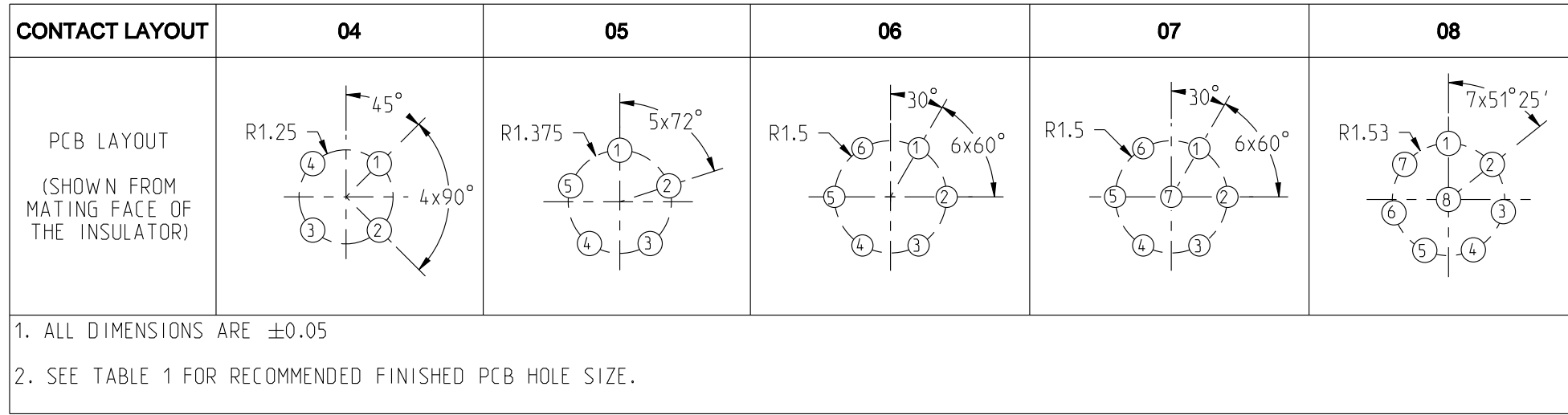

CONTACT PCB TAIL SIZE DIA	FINISHED PCB HOLE SIZE DIA
0.5	0.75

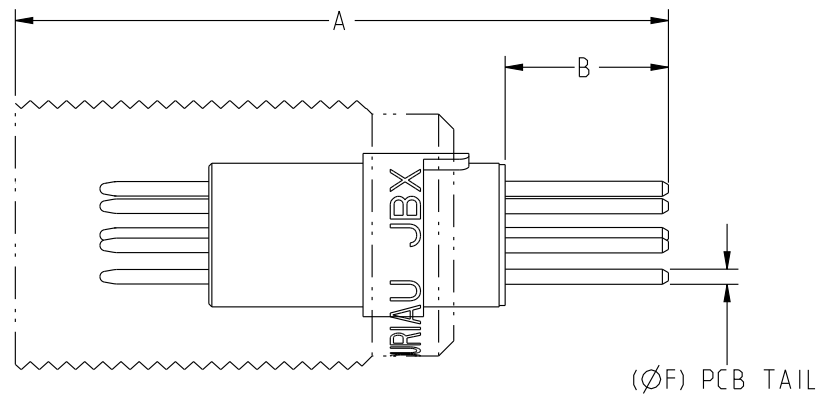

SAMPLE ASSEMBLY FOR INFORMATION

LAYOUT	04	05	06	07	08
A	24.3			21.6	
B	5.9			5.4	

ORIGIN	COUNTRY	JURISDICTION	CLASSIFICATION
X	FR	Not listed	N/A
	US	EAR	ECCN =EAR99

These commodities, technology or software are exported from the United States in accordance with the Export Administration Regulations. Diversion contrary to U.S. law is prohibited.

LINEAR MEASURE:	$\frac{mm}{INCH}$ mm (INCH)
THIRD ANGLE PROJECTION	
TOLERANCES UNLESS OTHERWISE SPECIFIED	
No. OF PLACES	mm [INCH]
ONE PLACE	$\pm 3 [\pm .1]$
TWO PLACES	$\pm 0.5 [\pm .02]$
THREE PLACES	$\pm 0.25 [\pm .010]$
ANGLES $\pm 1^\circ$	

DRAWING TITLE		JBX, SIZE O, MALE INSULATOR, PCB CONTACT	
CAT NO.		JBX01NSMP	
CAGE NO: 09922	SIZE: B	CUSTOMER	SOURIAU
INTERPRET THIS DRAWING IN ACCORDANCE WITH ASME Y14.5M - 1994.			
WWW.SOURIAU.COM		DRAWING SCALE: NA	
2 OF 2		DRAWING NO. REV	
		JBX01NSMPC B	

B

A